

Development of Measurement Method for Testing the Shielding Properties of Textiles and Analysis of Availability of the Measurement System

Katalin Németh-Erdódi, Tibor Gregász

Faculty of Light Industry and Environmental Engineering, Óbuda University
erdodi.katalin@rkk.uni-obuda.hu, gregasz.tibor@uni-obuda.hu

***Abstract:** Importance of protective everyday clothing is continuously increasing since environmental risks have come to the fore. Growing of environmental risks caused by electro smog is our day-by-day problem. Number of pieces of high frequency equipment is increasing and, though the manufacturers do their best to decrease electromagnetic radiation, it is not yet undoubtedly proved that this radiation is not harmful to health.*

Research works and tests have not yet proved undoubtedly either the direct effect of electro smog to health or that of its harmlessness. Therefore it is understandable that people want to use all equipment that can reduce the eventual negative effect of this radiation. A group of such equipments consist of textiles that are able to shield electromagnetic radiation to a certain degree.

***Keywords:** Electro smog, shielding capacity against electromagnetic radiation, protecting textiles*

1 Introduction

Being at home or pursuing our profession in our workplace, we are continuously exposed to electromagnetic radiation. The term “electrosmog” includes all the types of radiations surrounding us, caused by the magnetic field of the Earth, high voltage transmission lines, electric equipments working close to us, even cellphones too. The frequencies, intensities of these radiations and fields are different, as well as their character (electric, magnetic or coming from large distance), and the electrosmog created by them has various effects.

Aim of our research work is to develop textile products for clothing that are able in some degree to filter the electromagnetic radiation reducing its eventual harmful effect. We wanted to develop woven fabrics that could be used in making

fashionable garments as materials of certain components (e.g. inlays) having this advantageous feature.

To test the radiation filtering ability we developed a measuring method adapted to an instrument basically available for measuring of electrosmog.

2 Introduction Some Measurement Methods for Testing the Shielding Effectiveness

2.1 Measurement of Effectiveness of Shielding (according to ASTM D4935)

This measurement unit works on principle of capacity. The instrument consists of two independent brass bells, separated by the test material^{1,2,3} Using the set-up shown in Fig. 1, capacity difference can be observed between an internal metallic (e.g. brass) conductive layer and the outer cell. One side of the instrument is coupled to a high frequency generator (making frequency oscillation), while the middle part is coupled to the measurement side. The material to be tested is placed between the two conductive layers (Fig. 1.b) and the impedance between the outer and inner conductive layers will be measured.⁴ [6].

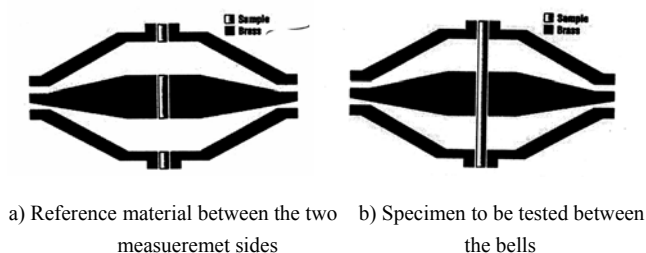

Figure 1: Measurement set-up working on principle of capacity [13]

¹ [13] Ogunsola, A: Harmonization of Shielding-Effectiveness Standards for Enclosures (www.ce-mag.com/archive/01-Spring/Ogunsola.html)

² J. Koprowska, M Pietranik, W. Stawski: New Type of Textiles with Shielding Properties

³ Mühl, T., Obolenski, B.: Textilien und elektromagnetische Strahlung (Grundlagen) Melliland Textilberichte 2004/3 190.- 192. o.

⁴ [6]: ASTM D 4935: Standard Test Method for Measuring the Electromagnetic Shielding Effectiveness of Planar Materials

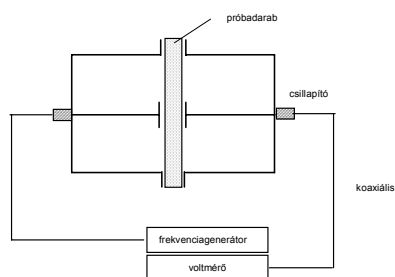

Figure 2: Measurement set-up working on principle of capacity

2.2 Measurement of Effectiveness of Shielding (accord to IEEE-STD 299/MIL-STD 285)

MIL-STD-285 and later standards The MIL-STD-285 method for evaluating shielding effectiveness was developed in the USA for military purposes, and was published in 1956. It is probably the most frequently referenced standard covering attenuation measurements for shielded enclosures within the frequency range of 100 kHz to 10 GHz. This standard defines the frequencies and electromagnetic field components which are subject to testing, and states the equipment required & the antenna configurations. The signal source is placed inside the tested enclosure, whilst the measurement device is located outside.

The methods for measuring shielding effectiveness described in MIL-STD-285 were later replaced by those in IEEE-STD-299. This document describes methods for measuring shielding effectiveness for enclosures, although with the smallest linear dimension of such enclosure being at least 2 m. [14]

The measurement range in this method is divided into 3 sub-ranges:

- low range - from 9 kHz (50 Hz) to 20 MHz – for the magnetic component (H),
- resonant range - from 20 MHz to 300 MHz – for the electrical component (E),
- high range - from 300 MHz to 18 GHz (100 GHz) – for the plane wave power (P).

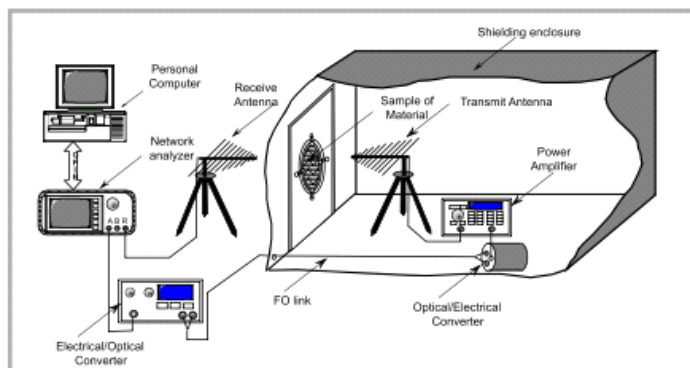

Figure 3: Adaption of the MIL-STD-285 method for attenuation measurement of thin materials [14]

Mühl and Obolenski carried out measurements on basis of the principle introduced above when they tested the effectiveness of shielding of textiles⁶. The specimen was placed in the gap of a metallic chamber in direct contact with the metallic wall. The electro magnetic field was created by logarithmic periodical aerials. The polarization plane of the electro magnetic field is vertical. Therefore they tested the specimen in two successive measurement turning by 90 grades.⁷

The measurement will be carried out both by covering the 40 x 40 cm opening with the textile specimen and without specimen. Effectiveness of the shielding can be determined by the ratio of electric power transmitted by the test material and the reference material. According to the literature effectiveness of shielding (SE) can be calculated in this way [15]:

$$SE = -10 \log(S_{\text{specimen}}/S_{\text{reference}}) \text{ (dB)} \quad (1)$$

S_{specimen} – power density measured with the to be tested specimen (W/m^2)

$S_{\text{reference}}$ – power density measured with the reference material (aluminium plate) (W/m^2)

⁵ [14] Tadeusz W. Więkowski Jarosław M. Janukiewicz: Methods for Evaluating the Shielding Effectiveness of Textiles, FIBRES & TEXTILES in Eastern Europe January / December 2006, Vol. 14, No. 5, pp. 18-22

⁶ [15] T. Mühl; B. Obolenski: Textilien und elektromagnetische Strahlung; Melliand Textilberichte 2004./3. 190-192

⁷ EN 50 147/1: 1996, Anechoic chambers Part 1: Shield attenuation measurement

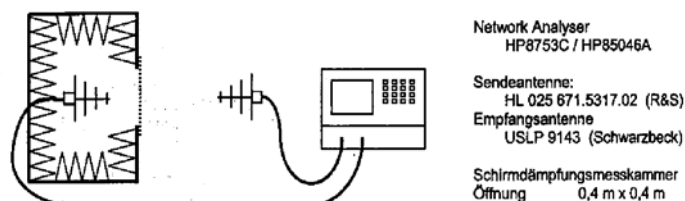

Figure 4: Measurement set-up[15]

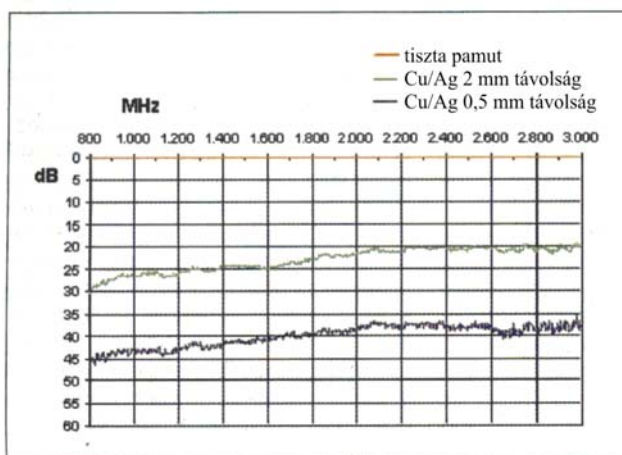

Figure 5: Shielding ability of various fabrics in the range of 800–3000 MHz[5]

Mühl and Obolenski (Textile Institute Aachen) used a woven fabric in their test series⁸ [5] cotton woven fabric which contained also yarns with metallic fibres of less than 30 μm diameter for giving electric conductivity to the fabric. They compared this test fabric to a pure cotton fabric. Shielding effect was tested in the range of 800–3000 MHz. They found that, if the fabric structure was the same, there was very little decreasing in shielding effect with increased frequency. Researchers of the University of Iași found too, that damping factor of various fabrics does not alter very much in the range of 900–2800 MHz.⁹ Damping factor depends on the fact whether direction of the conductive yarns is parallel with or perpendicular to the direction of vector E of the electro magnetic field.

⁸ Mühl, T., Obolenski, B.: Webware mit elektromagnetischer Schirmwirkung, Melliand Textilberichte 2004/5 348.-349. o.

⁹ Rau, M, Iftemie, A., Baltag, O., Costandache, D.: The Study of the Electromagnetic Shielding Properties of a Textile Material with Amorphous Microwire, Advances in Electrical and Computer Engineering 2011/1. p. 17-22.

3 Experimente

3.1 Method for Measuring of Shielding Effect

Measuring of effectiveness of shielding used for textile fabrics has been implemented by the method shown in Fig. 7. The radiation detector was placed in a shielded chamber covered by aluminium foil, only the display could be seen. This chamber contained the antenna and most parts of the receiving unit. An opening of 160×160 millimetre has been cut on one side of the chamber (taking the 125 mm wave length of the generated radiation into consideration) for the guided measuring of the radiation produced by the emitting antenna. This opening was covered by the piece of fabric to be tested which transmits the radiation in a grade depending on its shielding capacity. In the succeeding measurements the specimens were turned by 90 grades to test the differences in shielding effect according to the direction of warps and wefts.

3.2 The Measuring Set-up and the Measuring Environment

To create induced electromagnetic field in the discrete frequency range of 2,4 GHz we used a 10 dB high gain antenna with guided radiation. Type of the radiation detector is HF 58B; it is available to perform measurements in the range of 800 MHz to 1,5 GHz. This range includes all frequencies which are produced by the usual pieces of equipment like mobile phones, microwave ovens, Bluetooth, wireless telephones, etc., the radiation from which might be harmful for the human organism.



Figure 6: HF 58B Electro smog measuring set-up

This instrument has a logarithmic-periodic antenna. High frequency radiations are usually polarized, i.e. the plane of the waves is vertical or horizontal. Measuring in both planes is possible by changing the antenna position.

Radiation is produced by an oscillator. Electric polarization of the electromagnetic field is vertical. Intensity of the radiation is measured by a high frequency radiation measuring unit (it measures the power density). Measuring range in the 800 to 2500 MHz frequency range is 2 to 2000 $\mu\text{W}/\text{m}^2$. The instrument is available to measure power density S in mW/m^2 or $\mu\text{W}/\text{m}^2$. Not only the mean but also the peak values can be read on the digital display.

The measured values mean radiation performances according to the given frequency, relating to a theoretical area created by the dipole. The properly large distance of the emitting and the receiving antennas takes the distortion problems of „close ranges” into consideration so we can count on near real expansion. Position and polarization of the emitting and receiving antennas were tuned and unchanged during the measuring process.

Power density S_0 of the source of electromagnetic radiation in the environment of the radiation source could be measured in $\mu\text{W}/\text{m}^2$. Power density S_1 of the radiation that comes through the fabric put between the radiation source and the measuring antenna can be measured and it depends on the damping effect.

3.3 Evaluation

Shielding effectiveness (SE) against electromagnetic radiation can be described by the shielding or damping factor given in dB. Damping factor SE_i can be calculated from the ratio of power density measured without shielding ($S_{i \text{ without fabric}}$) and that with shielding produced by the tested fabric covering the opening of the chamber ($S_{i \text{ with fabric}}$):

$$SE_i = 10 \lg \left(\frac{S_{i \text{ without fabric}}}{S_{i \text{ with fabric}}} \right) \quad [dB] \quad (2)$$

Damping factor SE of the tested fabric is the mean of the momentary values:

$$SE = \frac{1}{n} \sum_{i=1}^n SE_i \quad [dB] \quad (3)$$

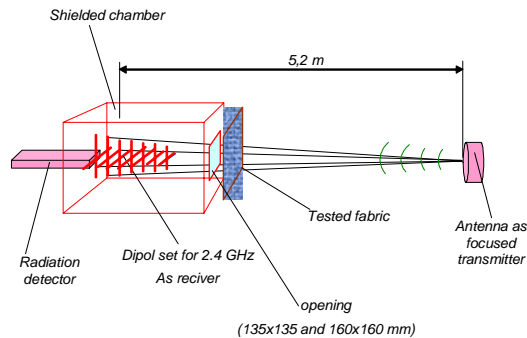

Figure 7: Sketch of the measuring set-up

3.4 Noises Burdening the Measuring Processes and their Handle

In order to minimize electromagnetic and other background noises during the measuring processes we implemented the following measures:

- There were only very few mobile radiation sources (mobile phones, computers, etc.) in the building in the late afternoon.
- Measurements were carried on in a ground-floor room which was separated from the street with several walls.
- It was not possible to eliminate radiation sources like light-sources and the transformers of the emitting and receiving units but the noise generated by them was, concerning their intensity and spectrum, static and their frequency was far from the measuring range.
- The transmitting antenna was placed in that way that there was no reflecting surface in the direction of and near the supposed radiation cone, so the antennas could be well positioned.
- Sizes of the chamber were relatively small (600×350×350 mm) but phenomena of near ranges created by inner reflections did not influence significantly the measured values.
- The two persons who carried out the tests could not be concerned as completely static damping medium. Their dielectric properties did not change during repeated measurements and produced only little changes between measurement series, though we tried to control it. However, their position and movement were out of the measuring area of radiation transmission thus their influence can be neglected
- After switching on the measuring system we waited at least half an hour to give time for warming up and to achieve stable and reproducible state.
- During each measurement we waited 5 seconds before reading the values in order to give time the system to becoming stable.
- Task of the two operators was always the same: they covered the opening by the test fabric always in the same method and they read the display again always in the same way which was not very easy because the values varied and this could be a significant source of error.
- Before the tests fabrics were conditioned in order to have the same humidity. This was important because results can be influenced by the dielectric behaviour of the test fabrics and we want to minimise this effect.

3.5 Analysis of the Measuring System, Tests of Repeatability and Reproducibility (R&R)

Because the principle of these tests is quite new there are presumably no earlier analyses carried on to estimate the uncertainties of such systems (instrument, operator, object, environment, method). In implementation of the tests we took care of quantification of uncertainty components following the principles of R&R method known in the automotive industry. To analyse the measuring system we

carried on test series of ten tests each, similarly to the real tests. In addition to the immediately repeated tests we set up and used the system at three different times, in order to be able to take the smaller differences in preparation and implementation of the tests (the long term components of fluctuations) into consideration.

Examination of Reproducibility

For this work we took for basis the R&R (Repeatability & Reproducibility) method used widely in the automotive industry.

The almost unvaried circumstances could be secured by a rather short period in which the tests were carried out. The measurement results received in the repeated tests of the same specimen were read off by the same person and in very short time. From the results of the repeated tests made on the same specimens ranges (R) were calculated. In an other time we carried out repeated tests again. The instrument was switched out and the whole measurement set-up was disassembled for hours, even for days. Measurements were carried out again sometimes by an other person under the same conditions. The many test results received by work of various persons and carried out in various periods were averaged and repeatability deviation could be calculated. This is already a value of uncertainty of the system since the averages of uncertainties reflecting the individual persons were averaged again

$$\hat{\sigma}_{mi} = \frac{\overline{R}}{d_2} \text{ thus } \sigma_{\text{repeatability}} = 1,88 \mu\text{W}/\text{m}^2 \quad (4)$$

(R means a range, i. e. it comes as difference of the highest and lowest value in a series of data and its value is proportional to the standard deviation. d_2 is a statistical constant for estimation of standard deviation, depending on the number of the repeated measurements.)

Examination of Repeatability

Here the uncertainties are quantified the origins of which are the effects coming from smaller deviations in set-up of the measuring system (change of operator, noise structure in the environment, some different in reading strategy, smaller changes in placing, not identified synergy effects, etc.).

Although we aimed to secure the same conditions when we set up the measurement unit repeatedly it could not carried out perfectly successful. Uncertainties coming from this fact could be evaluated by calculation the average of the results given by measurement series. From these averages the difference of the highest and lowest value the range of averages and the standard deviation can be calculated. This value shows in which degree can be the same average reproduced with concentrated measurement series.

$$\hat{\sigma}_{rp} = \frac{\overline{R_x}}{d_2}, \text{ thus } 2,106 \mu\text{W}/\text{m}^2 \quad (5)$$

(d_2 is here a statistical constant for estimation of standard deviation, depending on the test series carried on at various times and their means.)

Calculation of R&R Value

The R&R value can be calculated from the two variances mentioned above:

$$R \& R = \sqrt{\sigma_{re}^2 + \sigma_{rp}^2}, \text{ thus } 2,22 \mu\text{W}/\text{m}^2 \quad (6)$$

This result already takes also the short and long time fluctuations into consideration, contributing with this to the value of total uncertainty coming from the entire measurement system.

The repeatability and reproducibility deviations concern to the results of uncertainties of the electrical power. It can be ascertain that either the value of σ_{Mi} , which may be led back to the repeated measurements, the instrument and the interaction of the instrument and the specimen, or the value of σ_{Mi} , which may be led back to the measurement method, the variation of the environment or the operator, do not dominate. Both produced near the same value of variance components.

The question arises whether the R&R value is great or little. It is well known for experts using this method regularly that to answer his question is possible if the tolerance range concerning the product is known.

$$R \& R_{\%} = \frac{USL - LSL}{\hat{\sigma}_{R\&R}} \cdot 100\% \quad (\text{USL/LSL} - \text{Upper/Lower Specification Limit})$$

In our case only the absolute value of the test results were to be known, thus the well known percentile proportion can not be said. If the specification of a given product is at disposal percentile value of R&R can be calculated and it can be said whether the measurement set-up is available for depiction of the differences between tolerance ranges and for calculation of test results in the required accuracy. According to the generally accepted rating the measurement system is acceptable and available for the given task if R&R is less than 10%. In case this value is between 10 and 30 percent the system is acceptable only with reservation. Above 30% means too high uncertainty concerning the tolerance range so it should be developed or changed.

4 Testes Fabric Samples and their Results

Using the above presented method we wanted to determine how and at which value the shielding effect of various textile fabrics against electromagnetic radiation is influenced by metallized yarns placed into the fabric structure.

The test fabric was a striped woven fabric, made basically from polyester but first having metallized (PA 6.6 yarn covered by silver) yarns in both the warp and the weft system in certain distances (1 metallized yarn followed by 24 polyester yarns). Thus, it was a symmetric checked fabric. For further tests we changed the distances of metallized yarns in the weft: they were used in each 2nd or 4th weft insertion and also we used 2/2 weft insertion as well



II/1. sample



II/2. sample



II/3. sample



II/4. sample



II/5. sample



II/6. sample

Figure 8: Photos of the test fabrics

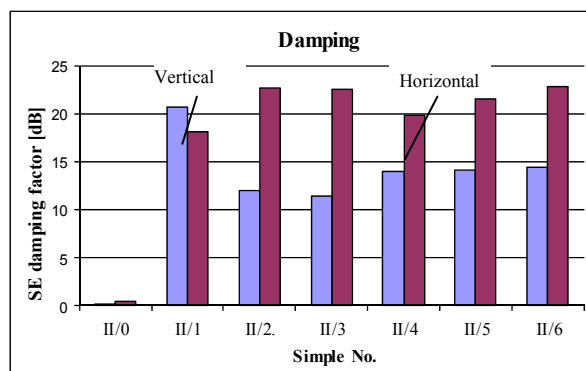

Figure 9: Electromagnetic damping factors measured on the samples

The following connection is valid between the shielding (values in dB) and the shielding effect (given in %) [2]:

TABLE I. Data of tested fabrics

Sample No.	Warp	Weft
0.	100% PES	100% PES
II/1.	24 times PES/ 1 metallized yarn	110 dtex PES (sequence: 24/1)
II/2.	24 times PES/ 1 metallized yarn	3 times 110 dtex PES FTF One 78/18 dtex metallized yarn
3.	24 times PES/ 1 metallized yarn	Each weft yarn: 78 dtex f18 metallized yarn
4.	24 times PES/ 1 metallized yarn	2 times 110 dtex PES FTF 2 times 78 dtex f18 metallized yarn
5.	24 times PES/ 1 metallized yarn	One 110 dtex PES FTF One 78 dtex f18 metallized yarn
6.	24 times PES/ 1 metallized yarn	Each weft yarn: 160 dtex twist
Basic warp:	74 dtex PES	-
Metallized yarn:	78 dtex f18 PA 6.6 with silver coating	
Basic weft:	-	110 dtex PES

TABLE II: Shielding levels

Shielding [dB]	Power density after shielding [%]	Ratio of absorbed radiation [%]
0	100	0
10	10	90
20	1	99
30	0,1	99,9
40	0,01	99,99
50	0,001	99,999
60	0,0001	99,9999

Two levels of electromagnetic field and shielding can be distinguished [2]:

- professional level: > 30 dB
- general level: < 30 dB

With this measurement method it can be decided whether or not the textile material has any electro magnetic filtering ability. The woven fabric made of 100% polyester produced shielding ability of practically 0 dB damping value. Fabrics tested in the same time and by the same person can be compared to each other, thus the above mentioned measurement system is available for indicative tests.

According to the test results, fabrics containing metallized yarns in the warp (one metallized yarn followed by 24 polyester yarn, the distance between the metallized yarns is 7 mm) present a shielding effect of 99 % comparing with fabrics made of 100 % polyester yarns. Fabrics with additional metallized yarns in the weft placed in the same set-up (7 mm distance between them) produce balanced shielding effect. The fabrics reach the 20 dB damping level and it meets the requirement of general work-clothes but not enough for effective protection against continuous and strong radiation in such work places like, for instance, antenna installation. This shielding level is acceptable for protection against electromagnetic radiations being present at home or in an office, in such environment it protects the human organism against the eventual harmful electro smog.

Shielding effect does not increase when the distance between metallized yarns is smaller than 7 mm. Further examination should be carried on with various radiation frequencies to determine the optimum density of metallized yarns (i. e. their number in 10 mm), their technical and economic parameters as well as the metallized yarn containing fabric construction in order to achieve optimal polarization when wearing the garment.

Conclusions

The developed measurement method is available to produce indicative evaluation of shielding ability against electro magnetic radiation for textile materials. The

reason of this reservation is that it was not possible to free the environment from noise thus the test results were burdened by environmental noise. A further problem was that these noises were not constant thus their degree and uncertainty also burdened the results. We are planning to develop a differentiated measurement method by which it could be possible to measure the power of electro magnetic radiation on the filtered and unfiltered sides of the specimen at the same time. From the difference of these two values the damping effect of the fabric could be given more precisely.

The measurements were carried out, according to experiences of other researchers, using the same frequency. Thus, changing of the frequency range did not cause significant change in the damping factor within the frequency range in which the usual tools like mobile phones, micro wave ovens, radio frequency remote controls, etc. work. Yarns with metallic content used in the fabrics shield against the electro magnetic effects, even if they take place only in one yarn system (warp or weft). The damping value depends also on the degree of the conductive yarn comparing to the direction of vector E of magnetic field strength. Further experiments are needed to determine the optimal number of conductive yarns in length unit, the technical and economic parameters of the conductive yarns as well as the direction of optimal polarization of the conductive yarns during wearing the garment.

References

- [1] Hannauerné Szabó A., Máthé K., Lázár K.: Elektroszög ellen védő funkcionális ruházat kifejlesztése, Pályázati tanulmány, 2007
- [2] 63/2004. (VII. 26.) ESzCsM rendelet a 0 Hz-300 GHz közötti frekvenciatartományú elektromos, mágneses és elektromágneses terek lakosságra vonatkozó egészségügyi határértékeiről.
- [3] Mühl, T., Kraus, E., Peifer, H.J., Obolenski, B.: Bekleidungstextilien mit elektromagnetischer Schirmwirkung - Technische Textilien 2005/2 pp.161.-163.
- [4] Mühl, T., Obolenski, B.: Elektromagnetisch schirmende Wirk- und Strickwaren Melliland Textilberichte 2004/7-8 587.- 588. o.
- [5] Mühl, T., Obolenski, B.: Webware mit elektromagnetischer Schirmwirkung, Melliland Textilberichte 2004/5 348.-349. o.
- [6] ASTM D 4935: Standard Test Method for Measuring the Electromagnetic Shielding Effectiveness of Planar Materials
- [7] Koczor Z et al: Minőségirányítási rendszerek fejlesztése, TÜV Rheinland Kiadó 2010
- [8] Koczor, Z., Némethné E. K.: Development of Methodology of Designing Work, Proceeding of Autex
- [9] K. Németh Erdődi, T. Gregász: Measuring of Protecting effect of Textiles against Electromagnetic Radiation, AUTEX Conference 8-10 June 2011, Mulhouse pp. 882-885 ISBN 978-2-7466-2858-8
- [10] Koczor, Z., Göndör, V., Gregász, T.: A mérési tevékenység folyamatos fejlesztése, Magyar Minőség, Vol. 5 (2005)

- [11]Rau, M, Iftemie, A., Baltag, O., Costandache, D.: The Study of the Electromagnetic Shielding Properties of a Textile Material with Amorphous Microwire, *Advances in Electrical and Computer Engineering* 2011/1. p. 17-22.
- [12]Stegmaier, T., Schmeer-Lioe, G., Vogel, H., Planck, H.: Schirmwirkung gegen elektromagnetische Wellen und Funkenentladungen, *Technische Textilien* 2006/1 pp. 57.- 60.
- [13]Ogunsola, A: Harmonization of Shielding-Effectiveness Standards for Enclosures (www.ce-mag.com/archive/01-Spring/Ogunsola.html)
- [14]Tadeusz W. Więckowski Jarosław M. Janukiewicz: Methods for Evaluating the Shielding Effectiveness of Textiles, *FIBRES & TEXTILES in Eastern Europe* January / December 2006, Vol. 14, No. 5 p.18-22.
- [15]T. Mühl; B. Obolenski: Textilien und elektromagnetische Strahlung; *Melliand Textilberichte* 2004./3. 190-192